

Motor HONDA GX-160

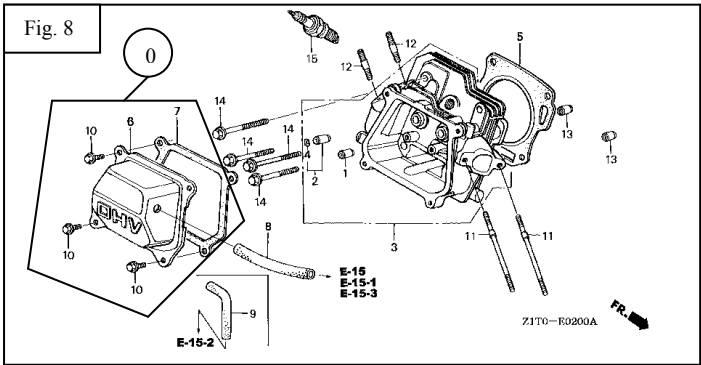
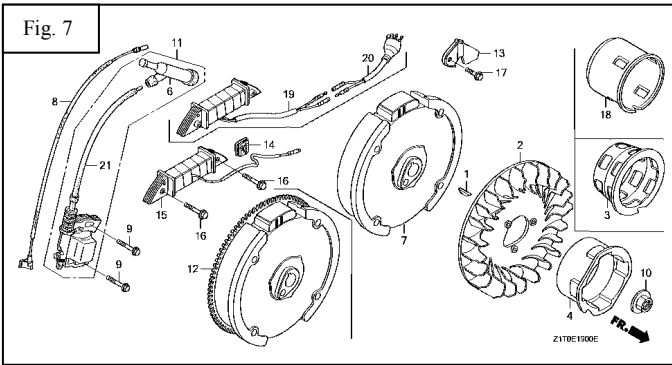
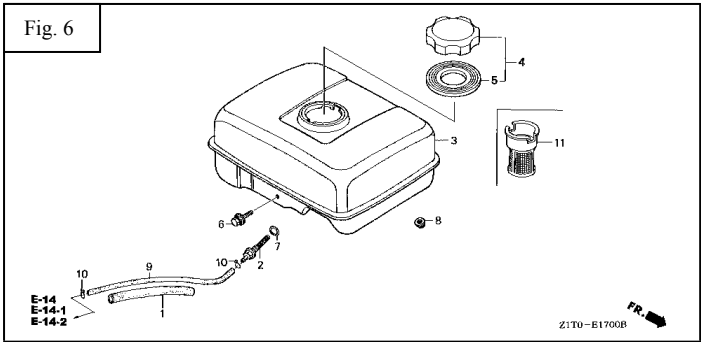
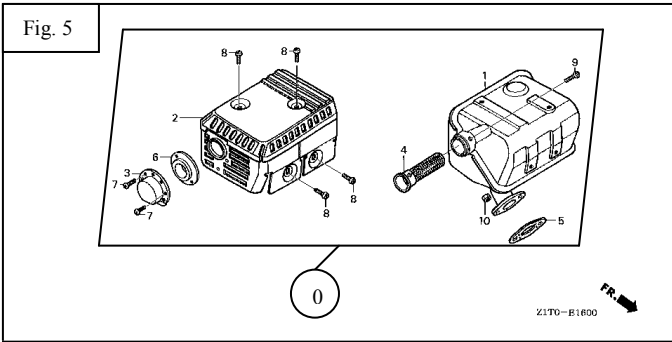
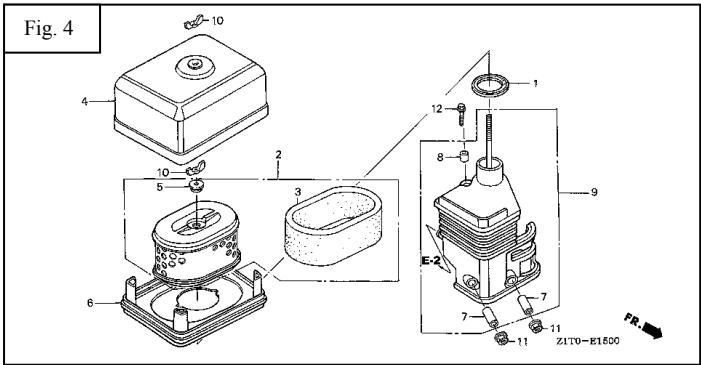
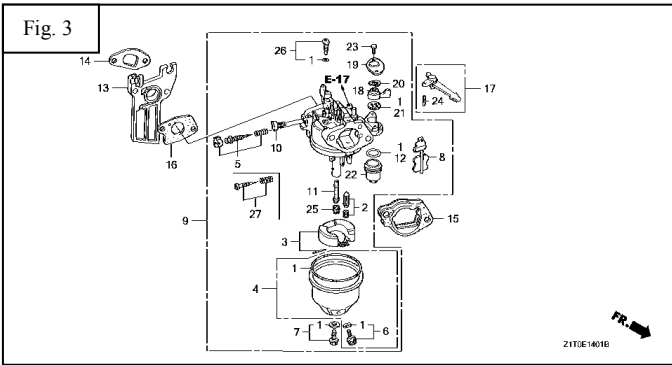
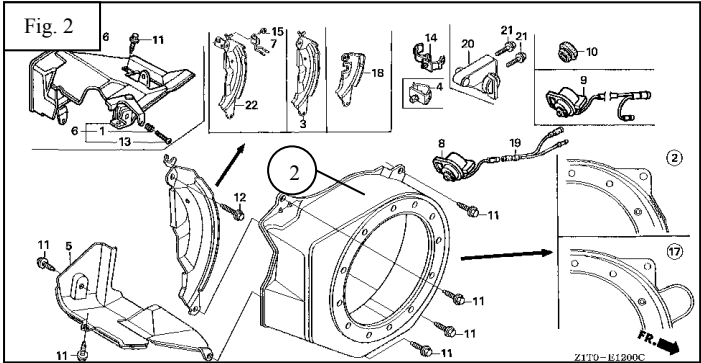
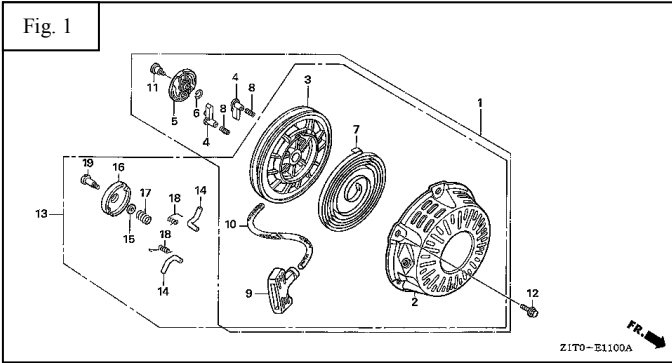
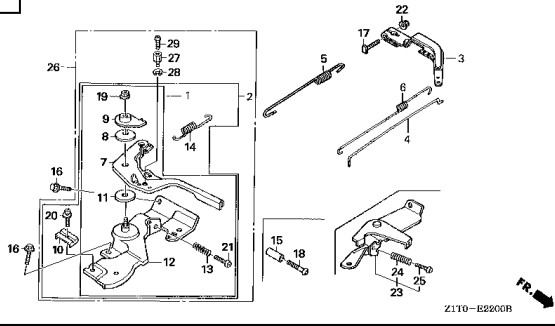
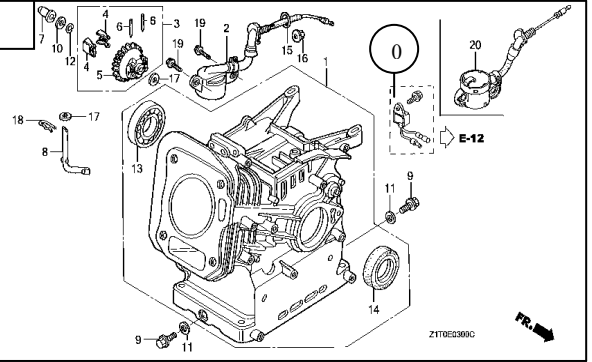

Fig. 9



Z110-E2200B

Fig. 10



Z110E2300C

Fig. 11

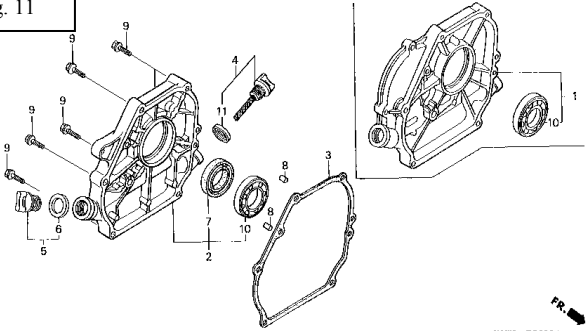

Z110-E0600A

Fig. 12

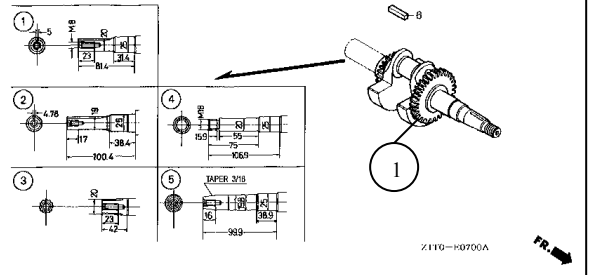

Z110-P0700A

Fig. 13

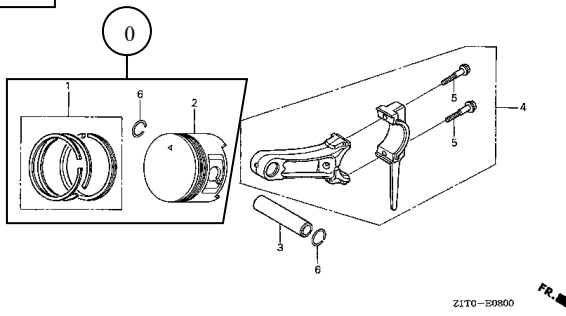

Z110-B0800

Fig. 14

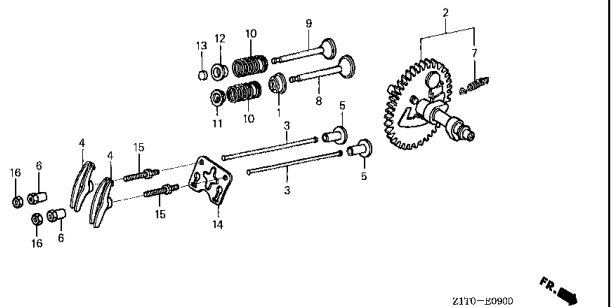

Z110-B0900

Nº	Código	Descripción	Uds.	P.V.P. Unidad	Nº	Código	Descripción	Uds.	P.V.P. Unidad
<u>ARRANQUE MANUAL (Fig. 1)</u>									
*	5630500	Kit de Juntas	1						
1	5630510	Arranque Completo	1						
<u>CUBIERTA VENTILADOR (Fig. 2)</u>									
2	19610-ZE1-010ZP	Cubierta Ventilador	1		8	5630917	Interruptor ON-OFF	1	
<u>CARBURADOR (Fig. 3)</u>									
9	5630502	Carburador	1		15	5630526	Junta Filtro Aire	1	
13	5630503	Separador Filtro	1		16	5630506	Junta Carburador	1	
14	5630504	Junta Separador	1						
<u>FILTRO AIRE (Fig. 4)</u>									
2	5630511	Elemento Filtro Aire	1		9	5630509	Soporte Filtro	1	
4	5630507	Tapa Filtro	1						
<u>ESCAPE (Fig. 5)</u>									
0	5630501	Cjto. Escape	1						
<u>DEPOSITO COMBUSTIBLE (Fig. 6)</u>									
3	5630512	Depósito-Tapón	1		4	5630513	Tapón + Junta	1	
<u>VOLANTE (Fig. 7)</u>									
2	5630514	Ventilador	1		7	31110-Z1T-003	Plato Magnético	1	
4	S/REF.	Vaso de Arranque	1		11	5630515	Bobina Alta + Cable	1	

<u>CJTO. CULATA (Fig. 8)</u>									
0	5630516	Cjto Tapa OHV	1		5	5630517	Junta Culata	1	
3	12210-Z1T-010	Cjto. Culata	1						
<u>CONTROL MANDOS (Fig. 9)</u>									
3	5630518	Palanca Regulador	1		1	5630519	Mando Aceleración	1	
<u>CILINDRO (Fig. 10)</u>									
1	12000-Z1T-810	Cilindro	1		8	5631320	Regulador	1	
2	5630930	Sensor Aceite	1		0	5630520	Alerta Aceite	1	
<u>TAPA CARTER (Fig. 11)</u>									
2	11300-Z1T-640	Cjto. Tapa Carter	1		4	5630935	Varilla Aceite	1	
3	5630521	Junta Tapa Carter	1		5	5630934	Tapón Aceite	1	
<u>CIGÜEÑAL (Fig. 12)</u>									
1	13310-Z1T-670	Cigüeñal	1						
<u>PISTÓN (Fig. 13)</u>									
0	5630522	Pistón + Segmentos	1		4	13200-Z0T-800	Cjto. Biela	1	
<u>ARBOL DE LEVAS (Fig. 15)</u>									
2	14100-ZL0-000	Arbol Levas	1		9	5630525	Válvula Escape	1	
5	5630523	Apoyo Empujador	2						
8	5630524	Válvula Admisión	1						

NOTA: En ésta lista están los recambios más habituales. Si se necesita algún otro “consultar”.

ALTERNADOR LINZ-SP 3,5 KVA

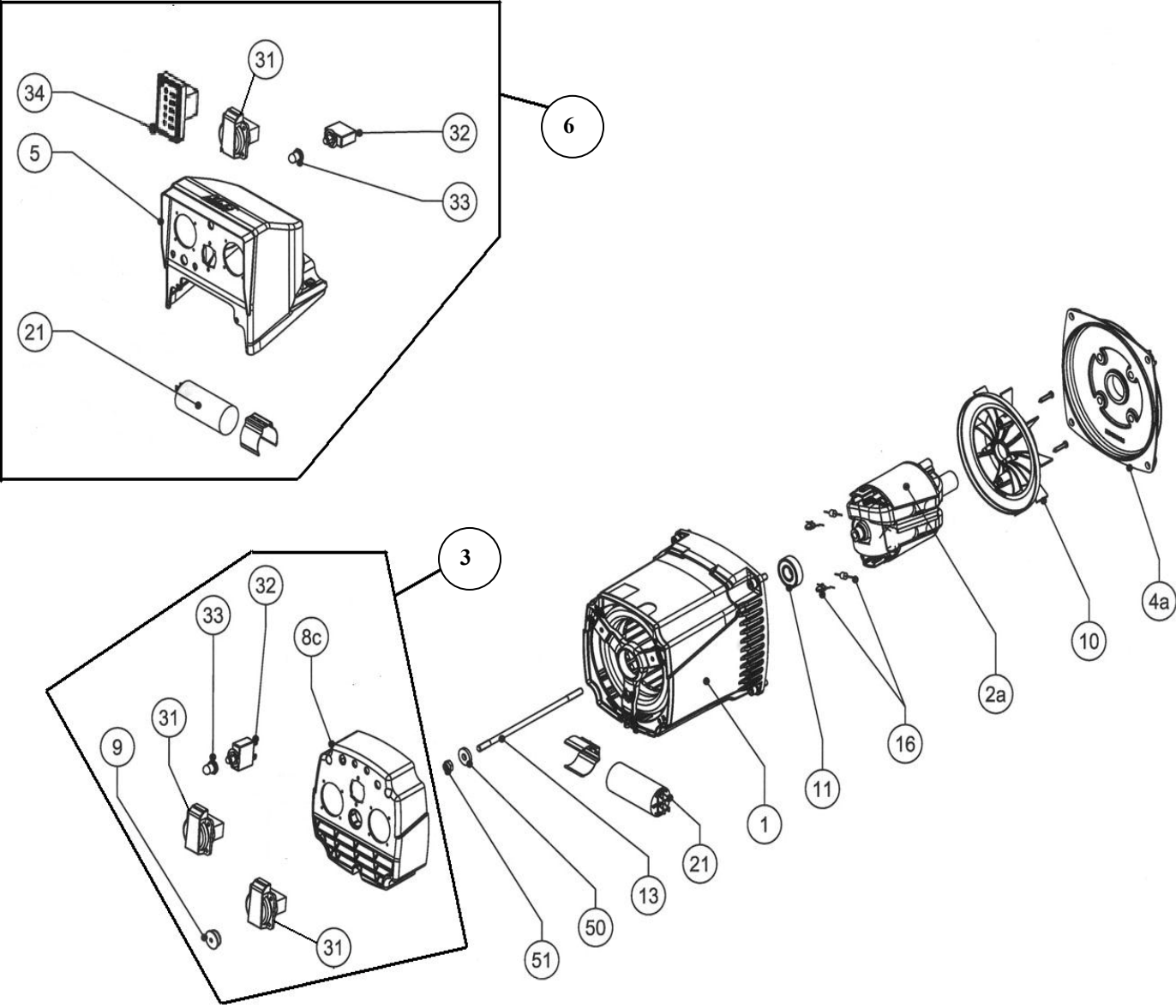

Nº	Código	Descripción	Uds.	P.V.P. Unidad	Nº	Código	Descripción	Uds.	P.V.P. Unidad
3	5621075	Carcasa C/Ench. (5 torn.)	1						
	5621080	Carcasa C/Ench. (3 torn.)	1						
6	5621130	Carcasa C/Diferencial	1						
10	5621105	Ventilador SP (2 tornillos)	1						
	5621100	Ventilador E1C	1						
16	5621025	Diodo-Varistor	2						
21	5621060	Condensador	1						
31	5810383	Base Schuko 16 AMP 2P +T	2						
32	5810201	Disyuntor 20 AMP	1						

NOTA: En esta lista sólo están los recambios más habituales. Si se necesita algún otro "consultar".